



**TRANSTECH**  
Parallel Systems

# TPE3 *PowerPC*™ G3/G4 PCI Card with PMC



- ❖ Industry standard PCI full length card
- ❖ *PowerPC*™ G3 or G4 with AltiVec™ technology (400MHz)
- ❖ 1 or 2MByte fast PBSRAM L2 cache on dedicated bus
- ❖ 64-512MB SDRAM with fast proprietary controller
- ❖ High performance PCI 2.1 compliant master/slave interface with dual DMA engines
- ❖ Modular expansion via IEEE P1386 PCI Mezzanine Card (PMC)
- ❖ Standard peripherals include 512kB flash boot ROM, 2kB NVRAM, serial port and timer
- ❖ Supports AMC PowerTAP™ JTAG in-circuit emulator
- ❖ Development support includes *PowerPC*™ Linux VxWorks™ BSP Free Basic Environment tools

The TPE3 *PowerPC*™ PCI card delivers an outstanding combination of computational and I/O performance in a compact, industry standard form factor. On its own, or as part of a multiprocessing system, the TPE5 is a powerful engine for embedded applications in the industrial, military and commercial market places

The TPE3 may be specified with either a *PowerPC*™ G3 (750) or G4 (7400) CPU. These devices use a highly advanced superscalar architecture to deliver exceptional integer and floating point performance. They include large on-chip instruction and data caches, a fast L2 cache controller, and a 66MHz 64-bit 60x bus interface. The *PowerPC*™ G4 benefits from improved memory bandwidth and an AltiVec™ 128 bit vector processing engine which can perform 4 single precision floating point operations per clock.

A 1 or 2Mbyte L2 cache is implemented using fast pipeline burst SRAMs. This is connected to the CPU by a dedicated 64-bit backside bus running at half the CPU core speed (200MHz for a 400MHz processor clock speed).

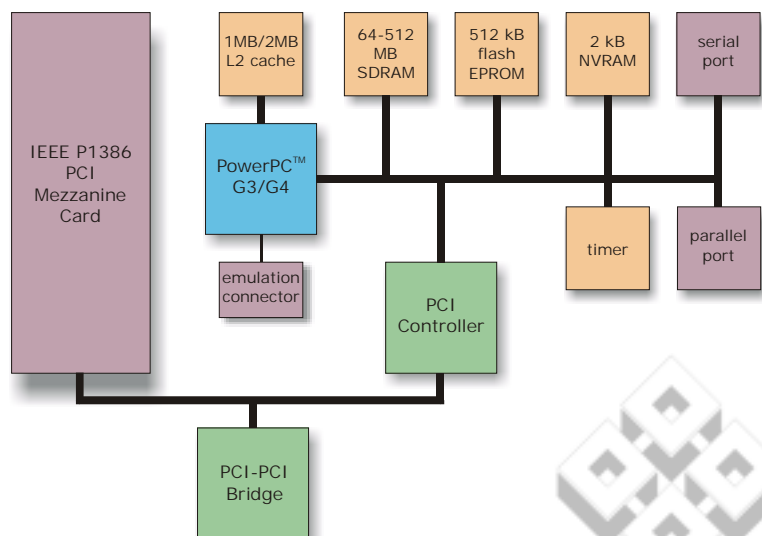

***PowerPC***™

The CPU is connected to the SDRAM memory by a proprietary controller which is optimised for low latency and high bandwidth data streaming.

The TPE3 PCI controller is a PCI 2.1 compliant initiator and target, and can generate and respond to configuration cycles. It uses byte invariant addressing and includes hardware endian-conversion. A pair of flexible DMA engines supports very high performance bus mastering.

As a target, it makes all on board resources visible to the host and other PCI initiators, including SDRAM, peripherals and control registers. Deep FIFO buffers allow burst transfers to and from SDRAM to achieve a bandwidth of 120Mbytes/sec sustained.

As an initiator, it allows the CPU and DMA engines to directly access other devices. The DMA engines can move data between the TPE3 and other devices at 120Mbytes/sec sustained, with full support for scatter/gather and unaligned transfers.

An on-board PCI bus segment connects the PCI controller to a PMC expansion module site and to the secondary port of a DEC/Intel 21152 PCI-PCI bridge; the primary port of this then provides connectivity to the main PCI bus.

The PMC site can accept any standard 32-bit 5 volt PMC module, and its interrupt output is routed to the PowerPC.

The TPE3 includes the standard peripherals required by mainstream RTOSs: a flash ROM for boot firmware, a small NVRAM, a timer and a serial port. Utilities are supplied to test and program the flash ROM and NVRAM, as are programming examples for the timer and serial port. A parallel port is also provided for simple digital I/O.

For development purposes, CPU operation can be fully controlled by the host through PCI registers which provide access to reset and interrupt functions, and bootstrap code may be located in SDRAM. Alternatively, the TPE3 may be configured to boot from flash ROM without host intervention.

Additionally, the TPE3 includes a JTAG TAP socket and adapter that is compatible with AMC's PowerTAP™ debugger. This offers power and functionality similar to a full in-circuit emulator.

The TPE3 ships with a CD-ROM packed with resources and tools, including:

- GNU C cross compiler for Win32 and Linux hosts;
- host drivers, libraries and utilities for Windows NT, Linux, DOS and Windows 95/98;
- comprehensive PowerPC runtime libraries with full source code;
- full product documentation.

## Specifications

### Processor

G3 (TPE3)	750 "Conan"
G4 (TPE3A)	7400 "Max"
L1 cache	32kb instr. / 32kb data

### Cache

L2	1MBytes (2MBytes option for G4) PBSRAM 200MHz
----	--

### Main Memory

Type	SDRAM
Size	64-512 Mbytes
Bus Speed	66MHz
Bursting	4-1-1-1-2-1-1-1

### Host PCI Interface

Compliance	PCI 2.1
Width	32 bit
Voltage keying	5V
Speed	33 MHz
Burst transfer rate	132 MByte/sec

### PMC Module Site

Compliance	PCI 2.2
Width	32/64 bit
Voltage keying	5V (3.3V option)
Speed	33/66 MHz

### Emulation

Interface	AMC PowerTAP™ compatible
Connector	low profile adaptor

### Mechanical

Board form factor	PCI full length add-in card
Size	312mm x 107mm
Weight	225 g
Expansion	IEEE P1386 PMC

### Environmental

Power dissipation	15W (TPE3), 17W (TPE3A)
Operating temperature	0 to 55 °C
Storage temperature	-10 to 85 °C
Operating humidity	5% to 75% non condensing
Storage humidity	5% to 95% non condensing

### Software

- PowerPC™ Linux 2.2/2.4 with fast TCP/IP over PCI
- Free Basic Environment Tools
- VxWorks™ BSP
- hosting support for Windows NT, Linux, DOS and Windows 95/98/2K

## Ordering Information

**Part No.**                      **Key**  
**TPE3-XXX-YYY**    **XXX = Processor speed**  
                                  **YYY = External memory**

### Options include:

- **400MHz processor speed**
- **External memory fit**  
(64/256/512MBytes)



**TRANSTECH**  
 Parallel Systems

### Transtech Parallel Systems

PO Box 2026  
 Maidenhead  
 Berkshire SL6 8GZ  
 United Kingdom

**Tel: +44 (0) 1628 627727**  
**Fax: +44 (0) 1628 627729**  
**email: sales@transtech.com**

© Copyright 2001 Transtech Paraleel Systems Ltd. Document Reference TPE3141101.  
 Transtech reserves the right to alter specifications without notice, in line with its policy of continuous development.  
 Transtech cannot accept responsibility to any third party for loss or damage arising out of the use of this information.  
 Transtech acknowledges all registered trademarks.